

1	2	3	4	5	6	7
				FOR 客户名称	APPROVED 客户确认签字	ATTN 销售负责人

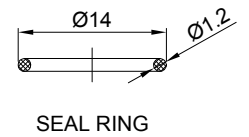

PART NUMBER: LAS2GQF-□■/◎/※

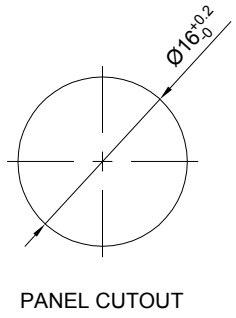
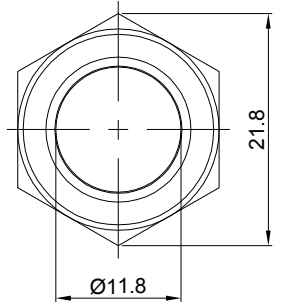
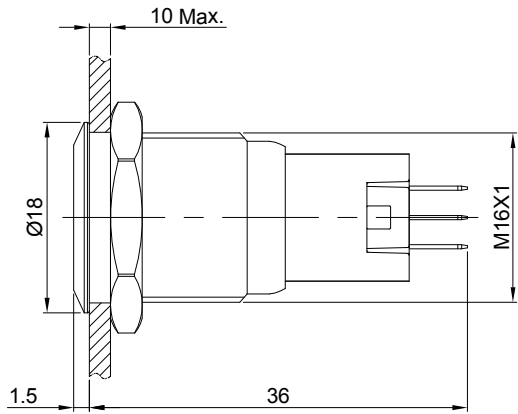
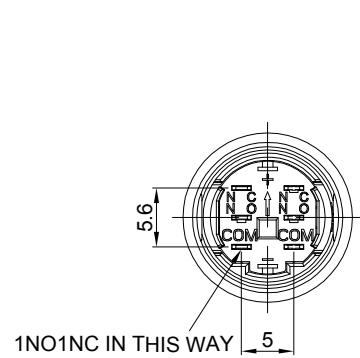
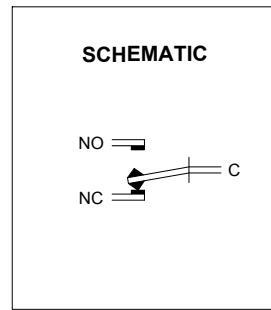

"□"	CONTACT STRUCTURE
11	1NO 1NC
22	2NO 2NC

"■"	OPERATION MODE
NO LETTER	MOMENTARY
Z	LATCHING

"◎"	CRUST MATERIAL
S	STAINLESS STEEL
A	AL ALLOY(BLACK)
N	NICKEL-PLATED BRASS

"※"	IP CLASS
NO LETTER	IP40
FP	IP67

SPECIFICATIONS:

- SWITCH RATING: $U_i: 220V, I_{th}: 3A$.
- MECHANICAL LIFE: $\geq 200,000$ cycles.
- ELECTRICAL LIFE: $\geq 50,000$ cycles.
- INITIAL CONTACT RESISTANCE: $\leq 50m\Omega$.
- INSULATION RESISTANCE: $\geq 100M\Omega(500VDC)$.
- DIELECTRIC STRENGTH: 1,500V, RMS 50Hz, 1min.
- OPERATING TEMPERATURE: $-25^{\circ}C \sim +55^{\circ}C$ (NO FREEZING, KEEP THE AIR FLOWING AROUND PUSHBUTTON).
- OPERATING FORCE: MOMENTARY: 1.2~1.8N(1NO1NC), 1.4~2N(2NO2NC).
LATCHING: 2.3~2.8N(1NO1NC), 2.5~3N(2NO2NC).
- OPERATING TRAVEL: ABOUT 2.8mm.
- TORQUE: 0.6Nm Max. APPLIED TO NUT.
- FRONT PANEL PROTECTION DEGREE: IP40/IP67.
- TERMINAL TYPE: PIN TERMINAL(1.8X0.4mm).
- GENERAL TOLERANCE: 0-18mm ± 0.25 , 18-80mm ± 0.52 .

SINGLE-BREAKPOINT QUICK-ACTING CONTACT SWITCHES WITH THREE TERMINALS

- MATERIALS:**
- CONTACT: SILVER ALLOY.
 - BUTTON: ◎.
 - BODY: ◎.
 - BASE: PA.

BRAND 品牌		红波按钮制造有限公司			
ONPOW 欧宝龙®		ONPOW PUSH BUTTON MANUFACTURE CO.,LTD.			
TITLE 名称	LAS2GQ SERIES ANTI-VANDAL PUSH BUTTON		UNIT 单位	mm	
DWG NO. 图号	LAS2GQF	SCALE 比例	1.4 : 1	SIZE 图纸	A4
FILE NAME 档案名称	LAS2GQ不带灯.DWG	DRAWN 制图	HCP 2023/11/8	SHEET 张	1/1
		REV. 更改			1